

SFILO EXTENSION EXPANSION ZYLINDERSTUF	DIAMETRO DIAMETER DIAMETRE DURCHMESS [mm]	SPINTA THRUST POUSSEE KRAFT [kN]	(200 bar)
1	135	286	
2	120	226	
3	105	173	
4	90	127	
5	75	88	

Data:	2005/01/28
Cliente.Naz:	3020515-DK
Data ordine:	
MODIFICHE	
Data:	
Data:	
Data:	
Data:	
Data:	
Data:	
Data:	
Data:	
Data:	
Data:	
NOTE	
Elementi fosfatati allo zinco	

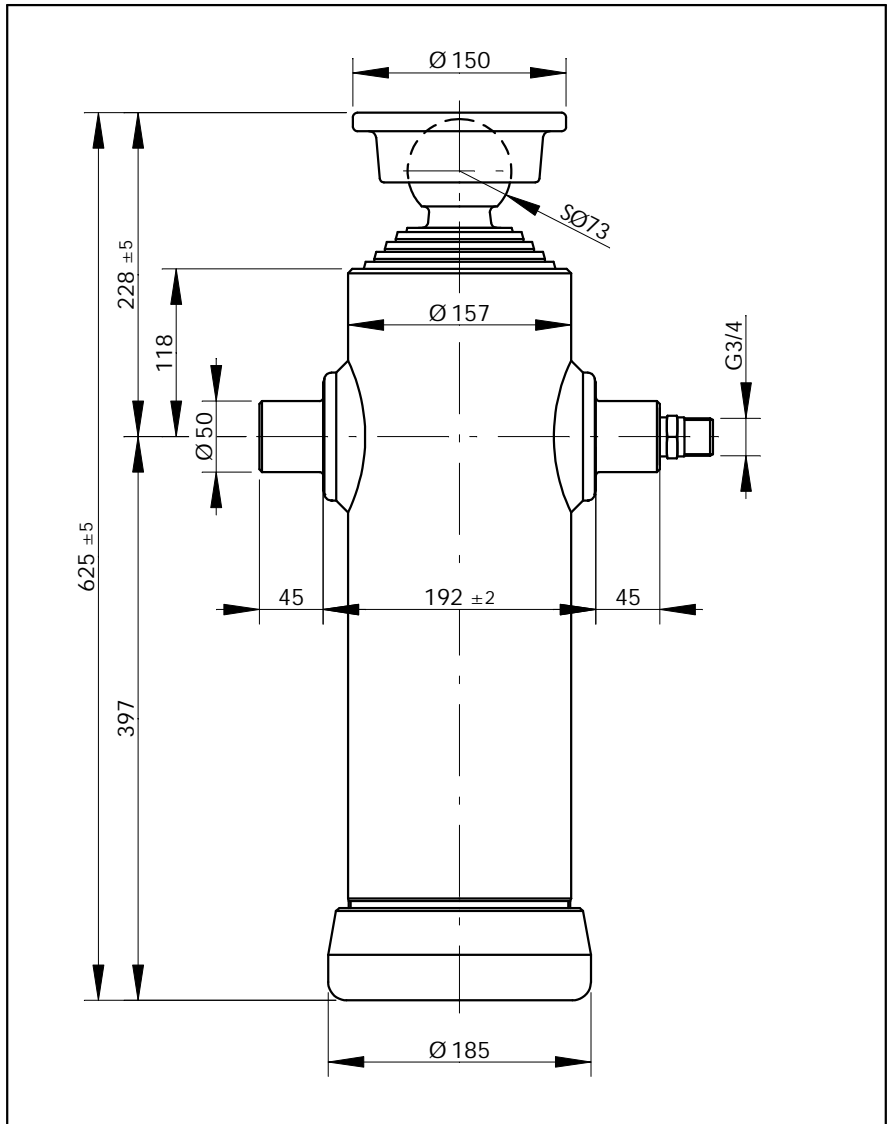

Scala - Scale - Échelle - Maßstab: 1:5

TIPO TYPE TYPE TYP	N. SFILATE EXTENSION N. N. DES HALLONGES STUFENZAHL	CORSA UTILE - POWER STROKE COURSE DE TRAVAIL - GESAMTHUB												MASSA MASSE MASSE	OLIO ASSORBITO OIL CONSUMPTION HUILE CONSOMMEE OELVERBRAUCH		
		I	II	III	IV	V	VI	VII	VIII	IX	X	tot					
		mm											kg			dm ³	
SL04/5 phz. 1SL045P	5	387	393	394	394	395								1963	67	17.6	16.9

CODICE CODE CODE BESTELL-Nr.	PRESSIONE DI LAVORO MASSIMA: MAXIMUM WORKING PRESSURE: PRESSION D'UTILISATION MAXIMUM: MAXIMUMBETRIEBDRUCK:	200 [bar]	SPINTA MASSIMA - MAXIMUM THRUST: POUSSEE MAXIMUM - MAX SCHUBKRAFT:	133 [kN]
	<p style="text-align: center;">Massa totale ribaltabile in [ton] Total mass tip-up in [ton] Masse totale rebatable en [tons] Gesamtkippmasse in [ton]</p>			
emesso: 2004.10.01 modello "Figurino"				

Realizzato:

Visto: