

FRONT END CYLINDER

OUTER COVER

5C-06660-174-5-M0345-0000N

5C1610174501AN

Tipping weight: 42-85 ton (\*\*)

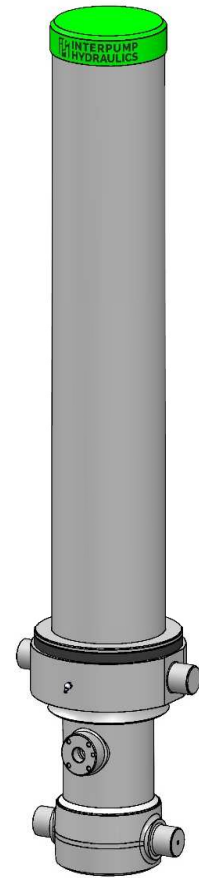
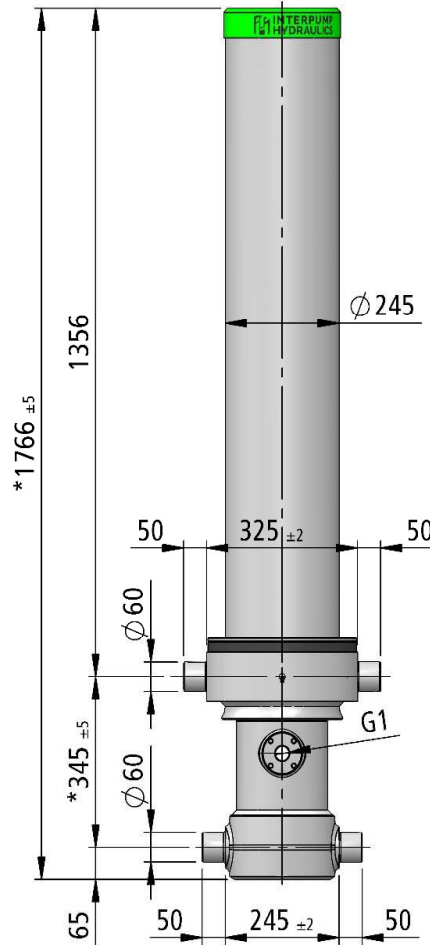
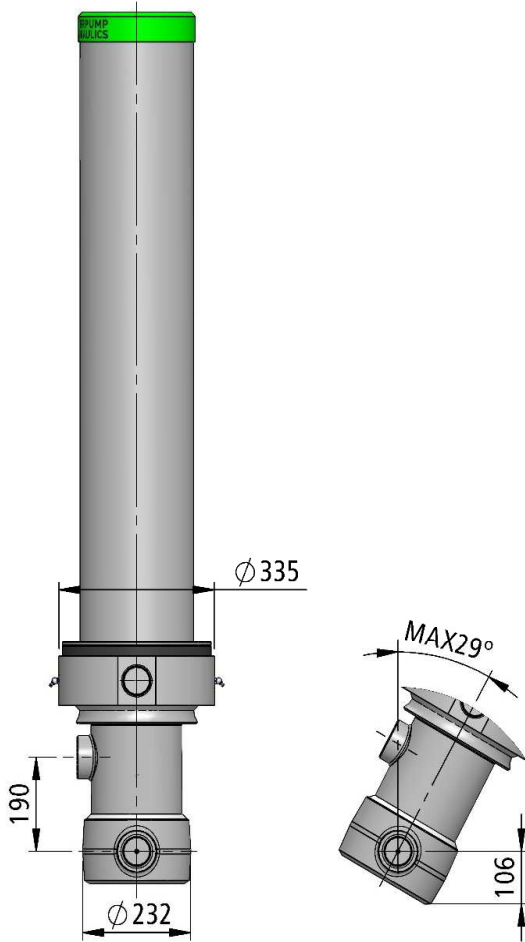

\* Mounting dimensions including 20 (-5;+30) mm pull out

Specifications

Total Stroke Length	6 660 mm	Maximum Pump Flow	Resulting Tipping Time	
Maximum Pressure (***)	250 bar	- with End of Stroke	220 L/min	→ 27 s
Weight	360 kg	- without End of Stroke	162 L/min	→ 37 s
Working Volume	100 L	- with End of Stroke below -20°C	154 L/min	→ 39 s
Residual Volume	8 L	- without End of Stroke below -20°C	113 L/min	→ 53 s
Max Cyl. Force - Start Tipping	295 kN	(***) Critical Cylinder Force Fully Extended (Buckling)	290 kN	↔ 380 bar

Extension	1	2	3	4	5	6	7	8	9	10	Guide kit:	Seal kit:
Rod diameter [mm]	174	154	135	116	98						K15F001745001	K25F001745001
Stroke length [mm]	1 328	1 330	1 334	1 334	1 334							

Technical notes

- ① The cylinder has been designed to provide only a linear pushing force.
- ① The cylinder is not a structural member and must not be used as a stabilizer or be subject to side or pulling load.
- ① Temperature range (-40; +100) °C
- ① Enamel RAL9005 two-component solvent semi-gloss finish 180 h spray salt test ISO 9227 rating 9 ISO 10289
- ① Chrome coating type CRN on rod stage 40 h spray salt test ISO 9227 rating 9 ISO 10289
- ① Standard (not hard chromed) stages must not be extended for over 30 min

All the information here reported are intended for further investigations by users with technical knowledge. The user, as manufacturer of the completed machinery which will incorporate the here described components, is the solely responsible for the final selection of the components. The user must carry out necessary research and tests on components to determine whether, by its design and construction, all performance, endurance, maintenance, safety and warning requirements are met. The user must assure the compliance of the completed machinery with all appropriate laws, directives, norms, industry standards. The cylinder will not prevent the dump body or trailer from rollover or lateral tilt. Cylinder rated pressure reflect only the capability of the pressure-containing envelope and not the force transmitting capability of mounting configurations. The ordinary use of telescopic cylinder will not require any coating since the telescopic stages are exposed to atmospheric agents only during the tip-up operation. Water jets must not be used on the upper part of stages (wiper area).

(\*\*) Tipping weight calculation-The body weight plus the max payload are the max tipping weight that can be raised by the cylinder. This value, calculated at the max pressure, is a rough indication of the tipping power of the cylinder and must be used only as a first criteria for the selection of the cylinder. The real tipping mass can only be calculated by the design engineer of the completed machinery, and must take into account the geometry of the dump body, the operating conditions and all the reasonably foreseeable uses.

Read and understand Mounting instructions, User manual, Oil specifications, User responsibility before use.

Subject to change without notice, no rights reserved.