

1 2 3 4 5 6

A

B

C

D

A

B

C

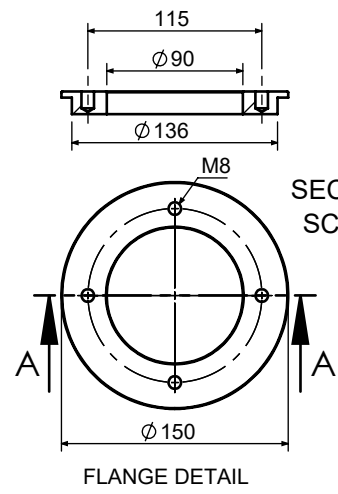
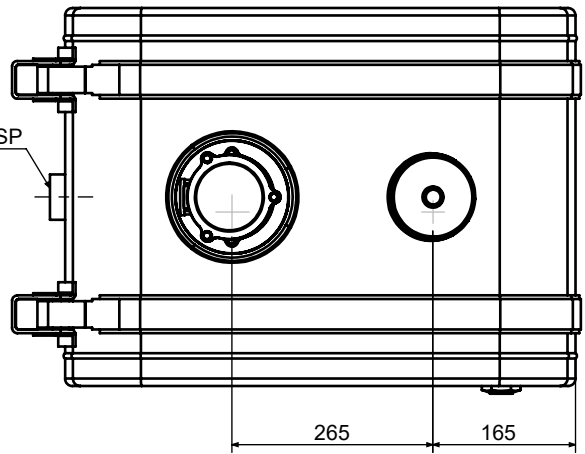
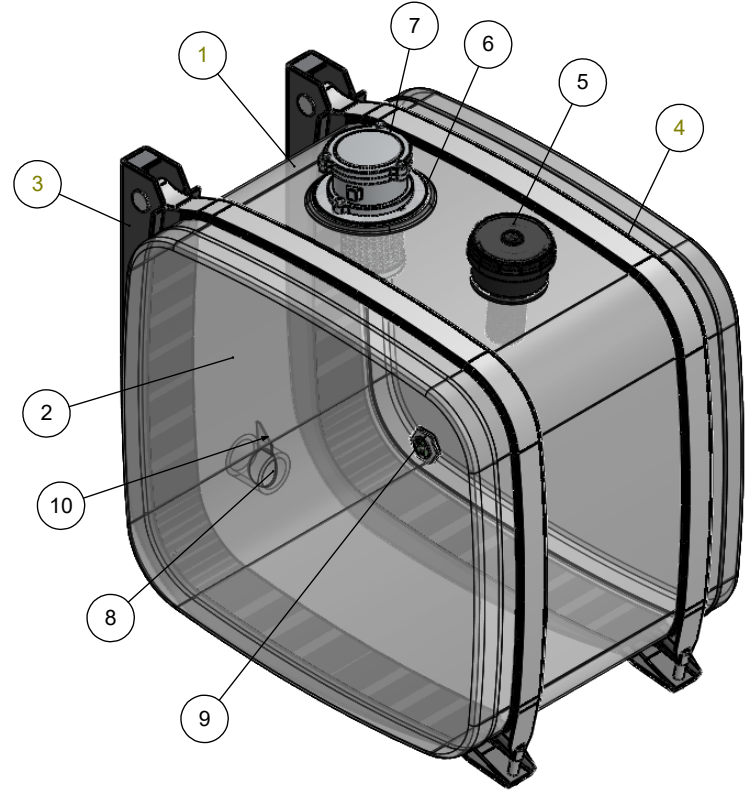
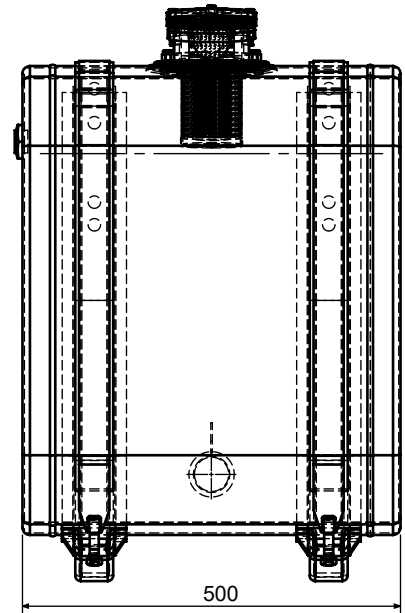
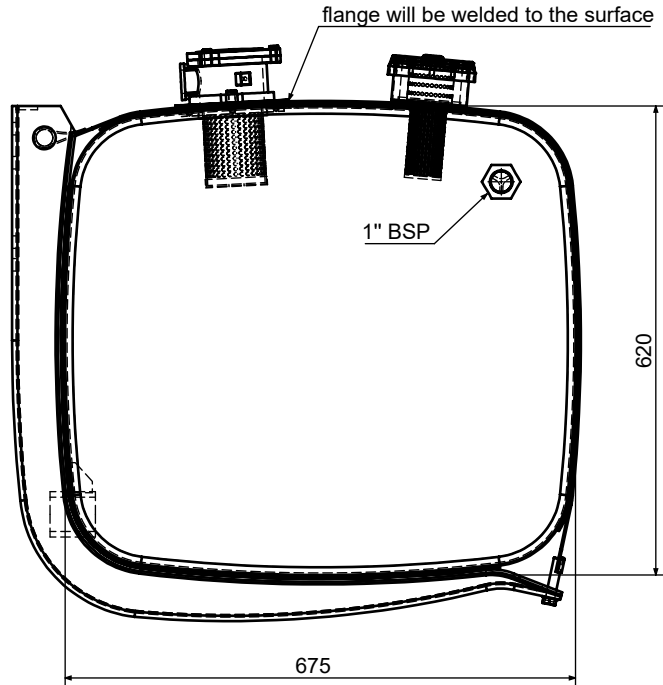

ITEM	QTY	DENOMINATION
1	1	Tank Body - 2,5 mm Aluminum
2	2	Side plate - 2,5 mm Aluminum
3	2	Bracket Steel - 6mm
4	2	Belt - 2 mm Chromium
5	1	Filling Neck
6	1	Connection flange
7	1	Immersion return filter
8	1	Suction Adapter 1 1/2" BSP
9	1	Level Indicator 1" BSP
10	1	Support

	Name Surname	Date	Signature	Weight:	200 LITER
Draw	Murat Oktay	06/08/2020		Material:Aluminum	
Control				Part Name: 620X670X500mm	
Scale	1/10			Explanation:Hydraulic Oil Tank (Top Flange)	

1 2 3 4 5 6