

TECHNICAL DATA



Light duty cylinder, ball - pins

Part Number

3105701605008

Tipping weight

17-29 ton

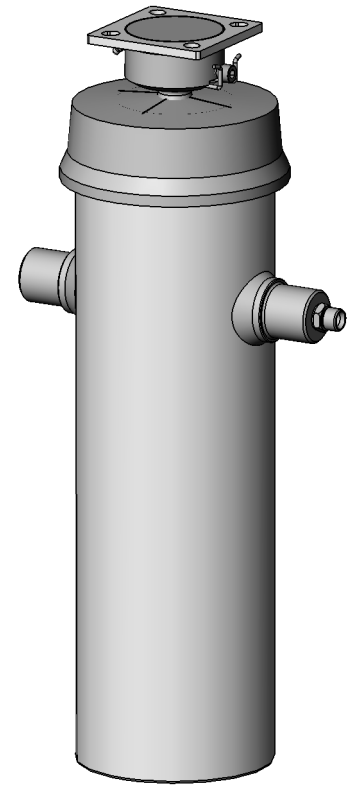
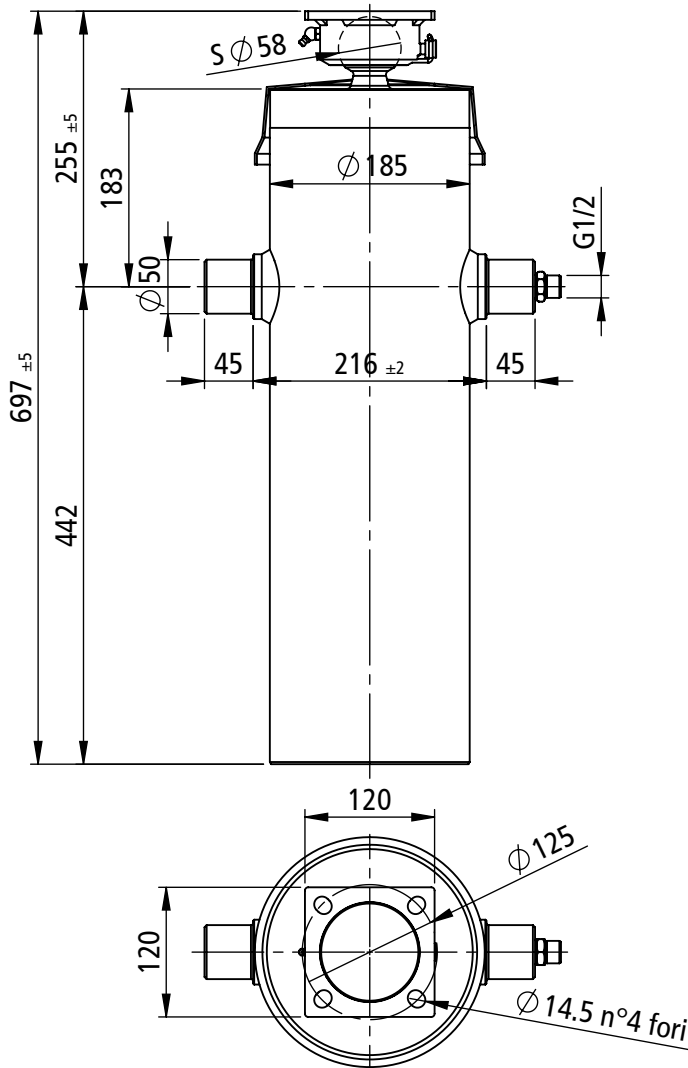

mounting dimension		255 mm + 20 mm min pull out				total stroke		2485 mm		max pressure		180 bar			
model: BL570 2485 160 5 CRN				code: 3105701605008				weight: 92 kg				1222 000997			
extension	1	2	3	4	5	-	-	-	-	--	--	number of stages: 5			
diameter [mm]	160	140	120	105	90	--	--	--	--	--	--				
stroke [mm]	497	503	500	499	486	--	--	--	--	--	--	total: 2485 mm			
thrust [kN]	362	277	204	156	115	--	--	--	--	--	--	max thrust admitted: 171 kN			
oil [dm³]	10.0	7.7	5.7	4.3	3.1	--	--	--	--	--	--	total: 30.8 dm³			

TECHNICAL NOTES AND SPECIFICATIONS

- The normal application of telescopic cylinder is to lift up tipping bodies, loaded with different materials, and consequently discharge this material whilst the cylinder is extended all along its stroke.
- The body weight plus the max payload are the max tipping weight that can be raised by the cylinder. This value, calculated at the max pressure, is a rough indication of the tipping power of the cylinder and must be used as a first criteria for the selection of the cylinder. The real tipping mass can only be calculated by the design engineer of the dump truck, and must take into account the geometry of the dump body and operating conditions. Never exceed the maximum thrust.
- Never exceed maximum pressure.
- The cylinder has been designed for loads along the longitudinal axis: the cylinder is a lifting device only and may not be used as structural member or be subject to side load.
- Chrome coating type CRN (40 h corrosion test ISO 9227-rating 9 ISO 10289 / minimum thickness: 15 µm) on telescopic stages.
- H.S.PENTA warranty does not apply to any kind of corrosion of coated or non-coated parts. See terms of warranty.
- Maximum extension speed less than 0.2 m/s.
- Hydraulic oil temperature admitted between -40°C and +100°C.
- In case the cylinders must be stored, do not remove the package. Store them in a dry place, not exposed to rain. Do not store the cylinders for more than 6 (six) months.
- Further specifications see mounting instructions, hydraulic oil specification sheet, user & maintenance manual.

REMARKS

[2013.06.14] [2013.06.14]

Chromed stages (Steli cromati)

REVISIONS

	01
	02
	03
	04