

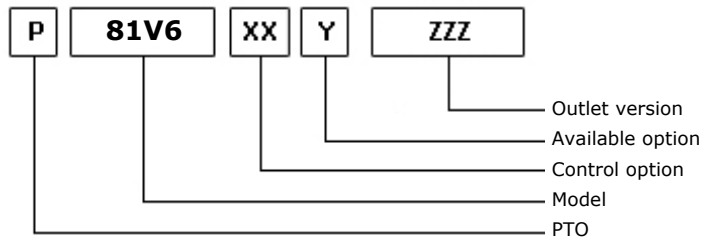

POSSIBLE SOLUTIONS

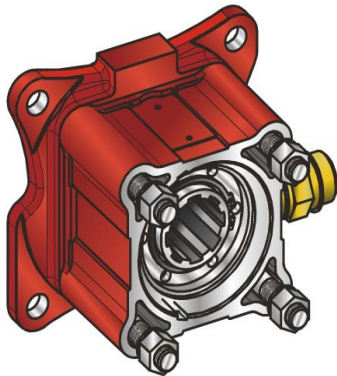

14/09/2015

TEC. SPECIFICATIONS

	Outlet 1		
Torque (NM)	1000	Replaces	81V1
Int. Ratio	1,00	Replaced by	
Teeth number	12		

CONTROL TYPE HYDROCAR

Electric Hydraulic Mechanic Fixed engagement Pneumatic Vacuum system

CONTROL VERSIONS (XX)

Type	82z1	Description
P	1	#Cmd M12x1.5 con raccordo
P	2	#Cmd M12x1.5 senz racc.

AVAILABLE OPTIONS (Y)

82z1	Description	Lubr. Kit	Switch Kit	Reinforced
0	#Non presente			<input checked="" type="checkbox"/>
4	#Con Kit interrut. Kostal		194KSP41000	<input checked="" type="checkbox"/>
5	#Con Kit interrut. Merit		194KSP19000	<input checked="" type="checkbox"/>
6	#Con Kit interrut. T.D.S.		194KSP40000	<input checked="" type="checkbox"/>

OUTLET VERSIONS (ZZZ)

82z1	Description
204	Pump drive SE 4-Bolts



Hydrocar
Hydraulic Energy

81V6

#PTO POS. H. D. VOLVO VT

Conversion kit

Pneumatic/Mechanic
Mechanic/Pneumatic
Electric control

#UNI da DIN 5462 (SE)

606X02Z0000

Flange kit

82z1

Description

606X03F0500	DIN 00 x PTO 0081
606X03F0600	DIN 10 x PTO 0081
606X03F0700	SP 1120 x PTO 0081
606X03F0800	SP 1300 x PTO 0081
606X03F0900	KIOKUTO "B"x 0081
606X03F1000	SP 1400 x PTO 0081

Switch kit

82z1

Description

194KSP19000	#Merit M16x1.5 N.C.
194KSP40000	#TDS M 16x1.5 N.C.
194KSP41000	#EATON N.C.



Hydrocar
Hydraulic Energy

81V6

#PTO POS. H. D. VOLVO VT

MATCHINGS

Brand	Range	Model	1st Gear ratio	Outlet	Application
NISSAN		VO514 B 0,8	13,16	Rear	V4
VOLVO		V 2214	0,00	Rear	V4
VOLVO		VT 1309	0,00	Rear	V4
VOLVO		VT 1414	0,00	Rear	V4
VOLVO		VT 1708 B	10,18	Rear	V4
VOLVO		VT 2009 B	0,00	Rear	V4
VOLVO		VT 2014	0,00	Rear	V4
VOLVO		VT 2214 B	0,00	Rear	V4
VOLVO		VT 2412 B	0,00	Rear	V4
VOLVO		VT 2514 B	0,00	Rear	V4
VOLVO		VT 2814 B	0,00	Rear	V4
VOLVO		VT 809	0,00	Rear	V4
VOLVO		VTO 2214 B	0,00	Rear	V4
VOLVO		VTO 2514 B 0,8	13,16	Rear	V4



Hydrocar
Hydraulic Energy

81V6

#PTO POS. H. D. VOLVO VT

